



Course organization

- **Introduction (Week 1-2)**
 - Course introduction
 - A brief introduction to molecular biology
 - A brief introduction to sequence comparison
- **Part I: Algorithms for Sequence Analysis (Week 3 - 8)**
 - Chapter 1-3, Models and theories
 - » Probability theory and Statistics (Week 3)
 - » Algorithm complexity analysis (Week 4)
 - » Classic algorithms (Week 5)
 - Chapter 4. Sequence alignment (week 6)
 - Chapter 5. Hidden Markov Models (week 7)
 - **Chapter 6. Multiple sequence alignment (week 8)**
- **Part II: Algorithms for Network Biology (Week 9 - 16)**
 - Chapter 7. Omics landscape (week 9)
 - Chapter 8. Microarrays, Clustering and Classification (week 10)
 - Chapter 9. Computational Interpretation of Proteomics (week 11)
 - Chapter 10. Network and Pathways (week 12,13)
 - Chapter 11. Introduction to Bayesian Analysis (week 14,15)
 - Chapter 12. Bayesian networks (week 16)

Chapter 6

Multiple sequence alignment

Chaochun Wei

Spring 2018

Contents

- 1. Reading materials**
- 2. Pairwise alignment using HMM**
- 3. Multiple sequence alignment**
 - **basic algorithms and tools**
 - **how to improve multiple alignment**



Reading materials

Book

Durbin, R., Eddy, S., Krogh, A., and Mitchison, G. (1998).
Biological Sequence Analysis. Cambridge University Press.
Chapter 5, 6
(Errata page: http://selab.janelia.org/cupbook_errata.html)



Pair HMM for local alignment

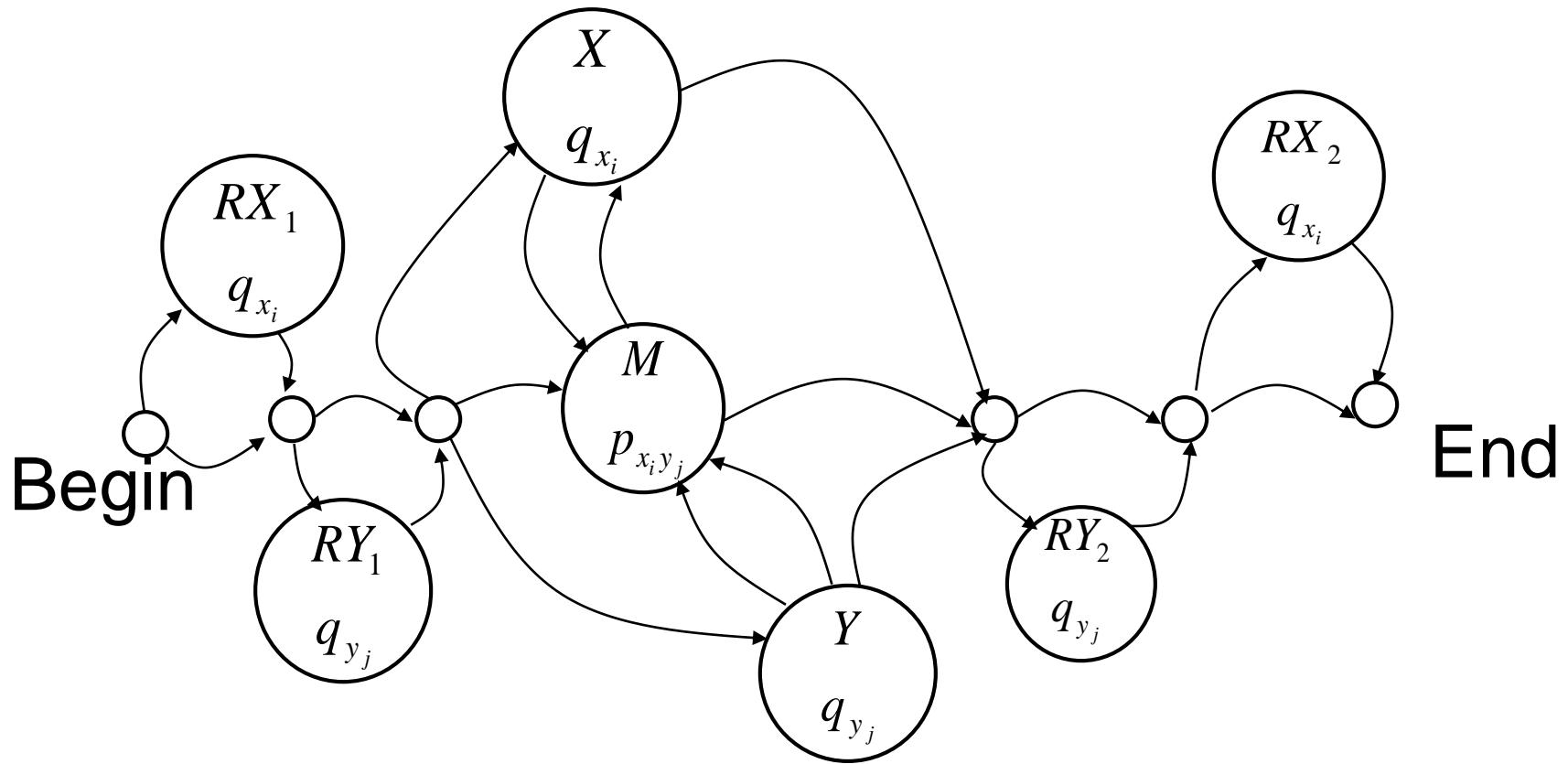



Multiple Alignment

- ① **What can one learn from a multiple alignment?**
- ① **How can a multiple alignment be used?**
- ① **How is a good multiple alignment obtained?**

Q9GPZ8_DICDI/51-243	..PEVGKKAT	EESIEELMNQ	IGDT...QML	FVTAGMGGGT	GTGGAAVIAS
FTSZ_ARATH/74-267	..PLLGEQAA	EESKDAIANA	LKGS...DLV	FITAGMGGGT	GSGAAPVVAQ
Q9XJ33_CYACA/92-292	..PEAGRVA	EESKEDIAKA	LQGG...DLV	FVTAGMGGGT	GTGAAPIVAD
FTSZ_MYCKA/9-202	..PEVGRXAA	EDAKDDIEEL	LRGA...DMV	FVTAGEGGGT	GTGGAPVVAS
FTSZ_CORGL/9-202	..PEVGRASA	EDHKNEIET	IKGA...DMV	FVTAGEGGGT	GTGAAPVVAG
Q9RWN5_DEIRA/4-197	..PKVGEEAA	VEDRDRIKEY	LDDT...DML	FITAGMGGGT	GTGSAPVVAE
FTSZ_MYCPU/11-202	..PEVGKKAA	EESIVEIKEK	LKGA...DMV	IITSGMGGGT	GTGASPIIAK
FTSZ_PORGI/17-211	..PEVARRAA	EASEADIRKI	LDDG.HTRMV	FVTAGMGGGT	GTGAAPVIGR
Q9S344_9BACT/15-205	..PARARQAA	EETLDDIKGM	LNDG..TKMA	FITAGMGGGT	GTGAAPVIAR
FTSZ_AQUAE/8-201	..PEVGEEAA	LEDIDKIKEI	LRDT...DMV	FISAGLGGGT	GTGAAPVIAK
Q19490_CAEEL/49-246	..YTIGKELI	DVVMDRVRL	TERCQSLQGF	LIFHSFGGGT	GSGFTSLVME
TBA1_SCHPO/53-250	..YTVGKEMI	DSVLERIRRM	ADNCSGLQGF	LVFHSFGGGT	GSGGLGALLE
O36040_SPIVO/27-224	..NTIGKEVI	DLVLDRIKRL	ADDCSGLQGF	IMFHSFGGGT	GSGGLGALLE
Q9UVR1_9ZYGO/30-229	..YTEGAELL	DQVLDTIRQD	VERCDLLSGF	QLCHSIAGGT	GSGMGSLMLQ
Q20823_CAEEL/45-245	..YEQGAEIV	DKVLSVIRRE	AEAADSLEGF	QLIHSLGGGT	GSGGLGSLIS
TBBP_DROME/46-243	..HTDGAAIL	DQVLENTRE	VESVDSLQGF	QLLHSIGGGT	GSGGLTSLIME
TBG_EUPAE/46-244	..YTDAEKVQ	DEILEMIDRE	ADGSDSLEGF	VLTHSIAGGT	GSGFGSYLLE
TBG_CHLRE/46-247	..YTQGEAVQ	ETLLDMIDRE	AEYCDSLEGF	NMCHSIAGGT	GSGMGSYMLE
TBG1_DROME/46-247	..YSQGEKLQ	EEVFDIIDRE	ADGSDSLEGF	ILCHSIAGGT	GSGMGSFIME
Q94771_9TRYP/46-249	..YEMGDTVQ	ETLFDMIERE	AENSDSLEGF	VLTHSIAGGT	GSGMGSYLLE
TBG_USTVI/46-246	..YAAGERVY	EEVMEMIDRE	AEGSDSLEGF	MLLHSIAGGT	GSGGLGSYLLE
TBG_SCHJP/46-247	..YAHAEKIF	EDIVDMIDRE	AEGSDSLEGF	SLLHSIAGGT	GSGGLGSYLLE
O15812_DICDI/46-244	..YKQGESFY	DDIFDMIDRE	ADGSESLEGF	LLTHSISGGT	GSGMGSYILE
O00849_TETHH/46-246	..YQEANKIQ	DDLLDMIDRE	ADTSDSF EAF	LLIHSIAGGT	GSGVGSYLLE
TBG_CAEEL/47-249	..YCQGQEVQ	EKIMDIIIRE	AENTNNDGI	LFTHSVSGGT	GSGTGSLLE
TBG_ENTHI/45-242	..YYTTEKMS	.EIEEIIDRE	VEHCDSLEGF	FFCHSICGGT	GSGGLGSKIME
TBG_YEAST/48-246	..YDIGTRNQ	DDILNKIDKE	IDSTDNFEGF	QLLHSVAGGT	GSGGLGSNLLE
TBG_CANAL/75-282	..YKYGTEEE	ETLLNLIDRE	VDKCDNLSNF	QLFHSVAGGT	GSGVGSKMLE
Q9NI44_9TRYP/49-280	..MEYGDKYI	DSITETVREQ	VERCDSIQSF	LIMHSLSGGT	GAGLGTRVLG
TBD_HUMAN/46-242	..SVHGPRHE	ESIMNIIRKE	VEKCDSFSGF	FIIMSMAGGT	GSGLGAFVTQ

Q9GPZ8_DICDI/51-243	..PEVGKKAT	EESIEELMNQ	IGDT...	QML	FVTAGMGGGT	GTGGAAVIAS
FTSZ_ARATH/74-267	..PLLGEQAA	EESKDAIANA	LKGS...	DLV	FITAGMGGGT	GSGAAPVVAQ
Q9XJ33_CYACA/92-292	..PEAGRVA	EESKEDIAKA	LQGG...	DLV	FVTAGMGGGT	GTGAAPIVAD
FTSZ_MYCKA/9-202	..PEVGRXAA	EDAKDDIEEL	LRGA...	DMV	FVTAGEGGGT	GTGGAPVVAS
FTSZ_CORGL/9-202	..PEVGRASA	EDHKNEIET	IKGA...	DMV	FVTAGEGGGT	GTGAAPVVAG
Q9RWN5_DEIRA/4-197	..PKVGEEAA	VEDRDRIKEY	LDDT...	DML	FITAGMGGGT	GTGSAAPVVAE
FTSZ_MYCPU/11-202	..PEVGKKAA	EESIVEIKEK	LKGA...	DMV	IITSGMGGGT	GTGASPIIAK
FTSZ_PORGI/17-211	..PEVARRAA	EASEADIRKI	LDDG.H	TRMV	FVTAGMGGGT	GTGAAPVIGR
Q9S344_9BACT/15-205	..PARARQAA	EETLDDIKGM	LNDG..	TKMA	FITAGMGGGT	GTGAAPVIAR
FTSZ_AQUAE/8-201	..PEVGEEAA	LEDIDKIKEI	LRDT...	DMV	FISAGLGGGT	GTGAAPVIAK
Q19490_CAEEL/49-246	..YTIGKELI	DVVMDRVRL	TERCQSLQGF		LIFHSFGGGT	GSGFTSLVME
TBA1_SCHPO/53-250	..YTVGKEMI	DSVLERIRRM	ADNCSGLQGF		LVFHSFGGGT	GSGLGALLE
O36040_SPIVO/27-224	..NTIGKEVI	DLVLDRIKRL	ADDCSGLQGF		IMFHSFGGGT	GSGLGALLE
Q9UVR1_9ZYGO/30-229	..YTEGAELL	DQVLDTIRQD	VERCDLLSGF		QLCHSIAGGT	GSGMGSLMLQ
Q20823_CAEEL/45-245	..YEQGAEIV	DKVLSVIRRE	AEAADSLEGF		QLIHSLGGGT	GSGLGSLNIS
TBBP_DROME/46-243	..HTDGAAIL	DQVLENTRE	VESVDSLQGF		QLLHSIGGGT	GSGLTSLIME
TBG_EUPAE/46-244	..YTDAEKVQ	DEILEMIDRE	ADGSDSLEGF		VLTHSIAGGT	GSGFGSYLLE
TBG_CHLRE/46-247	..YTQGEAVQ	ETLLDMIDRE	AEYCDSLEGF		NMCHSIAGGT	GSGMGSYMLE
TBG1_DROME/46-247	..YSQGEKLQ	EEVFDIIDRE	ADGSDSLEGF		ILCHSIAGGT	GSGMGSFIME
Q94771_9TRYP/46-249	..YEMGDTVQ	ETLFDMIERE	AENSLSLEGF		VLTHSIAGGT	GSGMGSYLLE
TBG_USTVI/46-246	..YAAGERVY	EEVMEMIDRE	AEGSDSLEGF		MLLHSIAGGT	GSGLGSYLLE
TBG_SCHJP/46-247	..YAHAEKIF	EDIVDMIDRE	AEGSDSLEGF		SLLSIAGGT	GSGLGSYLLE
O15812_DICDI/46-244	..YKQGESFY	DDIFDMIDRE	ADGSESLEGF		LLTHSISGGT	GSGMGSYILE
O00849_TETHH/46-246	..YQEANKIQ	DDLLDMIDRE	ADTSDSF EAF		LLIHSIAGGT	GSGVGSYLLE
TBG_CAEEL/47-249	..YCQGQEVQ	EKIMDIIIRE	AENTNNDGI		LFTHSVSGGT	GSGTGSLLE
TBG_ENTHI/45-242	..YYTTEKMS	.EIEEIIDRE	VEHCDSLEGF		FFCHSICGGT	GSGLGSKIME
TBG_YEAST/48-246	..YDIGTRNQ	DDILNKIDKE	IDSTDNFEGF		QLLHSVAGGT	GSGLGSNLLE
TBG_CANAL/75-282	..YKYGTEEE	ETLLNLIDRE	VDKCDNLSNF		QLFHSVAGGT	GSGVGSKMLE
Q9NI44_9TRYP/49-280	..MEYGDKYI	DSITETVREQ	VERCDSIQSF		LIMHSLSGGT	GAGLGTRVLG
TBD_HUMAN/46-242	..SVHGPRHE	ESIMNIIRKE	VEKCDSFSGF		FIIMSMAGGT	GSGLGAFVTQ



What can one learn from a multiple alignment?

- ⊗ **Some regions tend to be more highly conserved than others**
- ⊗ **Gaps are often clustered**
- ⊗ **May be conservation of types of residues (e.g. hydrophilic/hydrophobic) even if the residues themselves are variable**
- ⊗ **Can plot conservation to get an overview of how it varies**



Logo of a section of the tubulin protein family

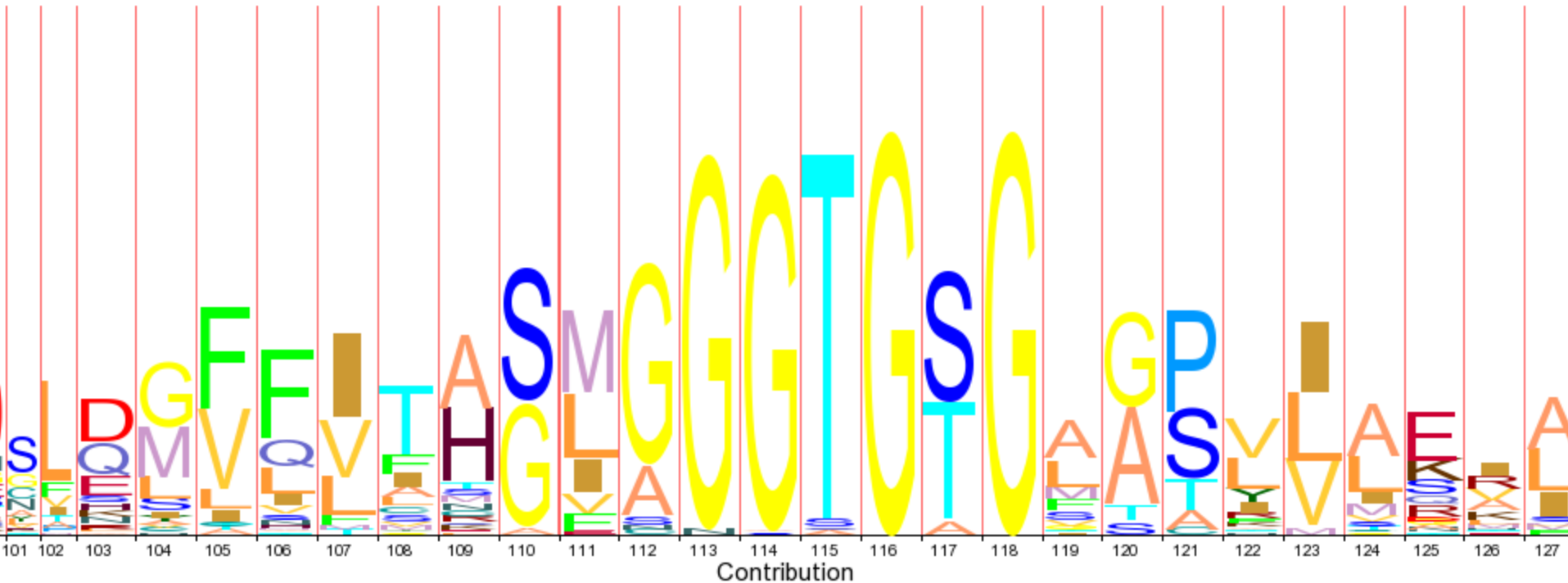



How can a multiple alignment be used?

- **Insights into protein structure/function**
 - Highly conserved positions/regions mostly likely required for function
 - Indels and hydrophilic regions usually on surface
- **Better, more sensitive searches**
 - Uses more information about protein's features to identify homologs
 - Position-specific scoring function

Table 2 - The log odds matrix for BLOSUM 62

	A	C	D	E	F	G	H	I	K	L	M	N	P	Q	R	S	T	V	W	Y
A	4	0	-2	-1	-2	0	-2	-1	-1	-1	-1	-2	-1	-1	-1	1	0	0	-3	-2
C		9	-3	-4	-2	-3	-3	-1	-3	-1	-1	-3	-3	-3	-3	-1	-1	-1	-2	-2
D			6	2	-3	-1	-1	-3	-1	-4	-3	1	-1	0	-2	0	-1	-3	-4	-3
E				5	-3	-2	0	-3	1	-3	-2	0	-1	2	0	0	-1	-2	-3	-2
F					6	-3	-1	0	-3	0	0	-3	-4	-3	-3	-2	-2	-1	1	3
G						6	-2	-4	-2	-4	-3	0	-2	-2	-2	0	-2	-3	-2	-3
H							8	-3	-1	-3	-2	1	-2	0	0	-1	-2	-3	-2	2
I								4	-3	2	1	-3	-3	-3	-3	-2	-1	3	-3	-1
K									5	-2	-1	0	-1	1	2	0	-1	-2	-3	-2
L										4	2	-3	-3	-2	-2	-2	-1	1	-2	-1
M											5	-2	-2	0	-1	-1	-1	1	-1	-1
N												6	-2	0	0	1	0	-3	-4	-2
P													7	-1	-2	-1	-1	-2	-4	-3
Q														5	1	0	-1	-2	-2	-1
R															5	-1	-1	-3	-3	-2
S																4	1	-2	-3	-2
T																	5	0	-2	-2
V																		4	-3	-1
W																			11	2
Y																				7

FTSZ_AQUAE/8-201 ..PEVGEEAA LEDIDKIKEI LRDT...DMV FISAGLGGGT GTGAAPVIAK
 Q19490_CAEL/49-246 ..YTIGKELI DVVMDRVRRL TERCQSLQGF LIFHSFGGGT GSGFTSLVME

* * * * *

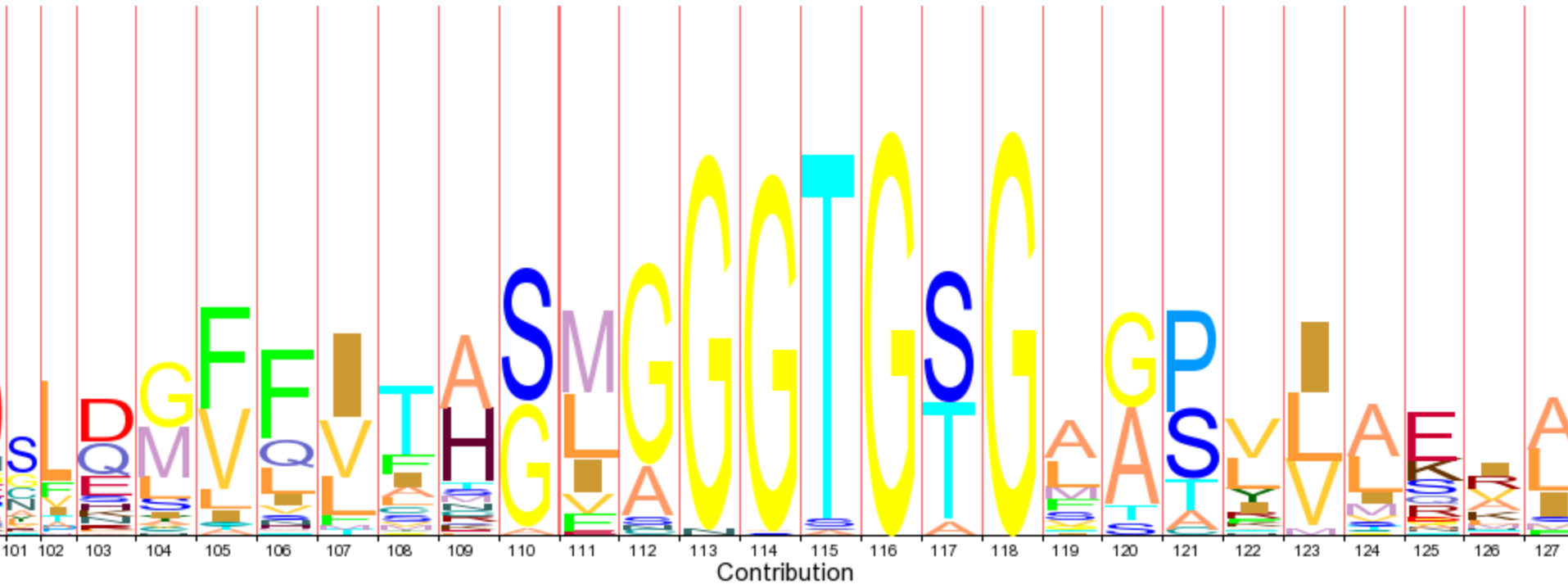

```

FTSZ_AQUAE/8-201      ..PEVGEEAA LEDIDKIKEI LRDT...DMV FISAGLGGGT GTGAAPVIAK
Q19490_CAEL/49-246  ..YTIGKELI DVVMDRVRRL TERCQSLQGF LIFHSFGGGT GSGFTSLVME
                    * *                *                *      **** * *
  
```



Scoring multiple alignments

- Common to use “sum of pairs” using the standard pairwise scoring
- An alignment of residue X in the query with the position Y of the alignment that contains the set Y_i of residues gets:

$$\begin{aligned}\text{Score}(X, Y) &= \sum_i s(X, Y_i) \\ &= \sum_i \ln[P(X, Y_i)/(P(X)P(Y_i))] \\ &= \sum_i \ln[P(X|Y_i)/P(X)]\end{aligned}$$



Sum-of-Pairs scoring (cont)

Score(X, Y) = $\sum_i \ln[P(X|Y_i)/P(X)]$

we can pre-compute the score for any X

➔ “Profile” for a multiple alignment

Important Point: highly variable position tend toward 0 for all scores, while highly conserved positions maintain the $s(X, Y)$ scores, increasing their contribution to the Score

Profile analysis: Detection of distantly related proteins

(amino acid/sequence comparison/protein structure/globin structure/immunoglobulin structure)

MICHAEL GRIBSKOV*, ANDREW D. McLACHLAN†, AND DAVID EISENBERG*

b

POS	PROBE	CONSENSUS	PROFILE																				
			A	C	D	E	F	G	H	I	K	L	M	N	P	Q	R	S	T	V	W	Y	+/-
1	EGVVL	V	3	-2	3	4	0	4	-1	3	-1	4	4	1	1	1	-2	1	2	6	-6	-2	9
2	LLSP	L	2	-2	-2	-1	3	0	-1	3	-1	6	5	-1	3	0	-1	3	1	4	1	-1	9
3	VVVV	V	2	2	-2	-2	2	2	-3	11	-2	8	6	-2	1	-2	-2	0	2	15	-9	-1	9
4	KEAT	A	6	-2	5	6	-5	4	1	0	5	-2	0	3	3	3	1	3	6	0	-6	-4	9
5	APLP	P	6	-1	0	1	-2	2	0	1	0	2	2	0	8	2	0	2	2	3	-5	-4	9
6	GGGG	G	7	1	7	5	-6	15	-1	-3	0	-4	-3	4	3	2	-3	6	4	2	-11	-7	9
7	SSQE	D	4	-1	7	7	-6	7	2	-2	2	-3	-2	4	3	6	1	6	2	-1	-6	-5	9
8	SSTP	S	4	4	2	2	-4	4	-1	0	2	-3	-2	2	7	0	1	10	6	0	-2	-4	9
9	VLVA	V	5	0	-1	-1	3	1	-2	7	-2	7	6	-1	1	-1	-3	0	2	10	-5	-1	9
10	KRRS	R	0	-1	1	1	-5	0	2	-2	8	-3	1	3	3	3	10	5	1	-2	7	-5	9
11	MLII	I	0	-2	-3	-2	7	-3	-3	11	-1	11	10	-2	-2	-1	-2	-2	1	9	-3	1	9
12	SSTS	S	4	6	2	2	-3	5	-1	0	2	-3	-2	3	4	-1	1	12	6	0	0	-4	9
13	CCCC	C	3	15	-5	-5	-1	2	-1	3	-5	-8	-6	-3	1	-6	-3	7	3	3	-13	10	9
14	KSQR	K	1	-2	3	3	-6	1	3	-2	7	-3	0	3	3	5	7	4	1	-2	2	-5	9
15	AAGS	A	10	3	4	3	-5	8	-1	-1	1	-2	-1	3	4	1	-2	7	4	2	-6	-4	9
16	TSDS	S	4	3	5	4	-5	6	0	0	2	-3	-2	4	3	1	1	9	6	0	-3	-4	9
17	GGSQ	G	5	1	6	5	-6	9	1	-2	1	-3	-2	4	3	4	0	6	3	0	-6	-6	9
18	YFLS	F	-1	2	-4	-3	9	-3	0	4	-3	6	3	-1	-3	-3	-3	1	-1	2	7	7	9
19	TTRL	T	1	-2	0	1	0	0	0	2	2	2	3	1	1	1	3	1	7	2	1	-2	9
20	FF.L	F	-2	-3	-6	-4	10	-4	-1	6	-4	9	6	-3	-4	-4	-3	-2	-1	3	7	8	4
21	SS.D	S	3	2	5	4	-4	5	0	-1	2	-3	-2	4	3	1	1	8	2	-1	-2	-3	4
22	S.SS	S	2	3	1	1	-2	3	-1	0	1	-2	-1	2	2	0	1	8	2	0	1	-2	4
23	. . . G	G	2	0	2	1	-2	4	0	0	0	-1	-1	1	1	1	-1	2	1	1	-3	-2	4
24	. . . D	D	1	-1	4	3	-2	2	1	0	1	-1	-1	2	1	2	0	1	1	0	-3	-1	4
25	. . . G	G	2	0	2	1	-2	4	0	0	0	-1	-1	1	1	1	-1	2	1	1	-3	-2	4
26	. AGN	A	6	0	4	3	-4	6	1	-1	1	-2	-1	5	2	2	-1	3	3	1	-5	-3	4
27	YNYT	Y	0	5	0	-1	5	-1	2	1	-1	0	-1	4	-3	-2	-2	0	3	0	3	6	4
28	EDDY	D	2	-2	9	8	-3	3	4	-1	1	-3	-2	5	-1	4	-1	1	1	-1	-6	0	9
29	LMAL	L	3	-5	-3	-1	6	-1	-2	6	-1	10	10	-2	0	0	-2	-1	0	6	-1	0	9
30	YNAW	N	4	1	3	2	0	2	3	-1	1	-1	-1	8	0	1	-1	2	1	-1	-1	2	9
.
48	SGNS	S	4	3	5	3	-4	7	0	-2	2	-4	-3	6	3	1	0	10	3	0	-2	-4	16
49	SSNY	S	2	5	2	1	1	2	1	0	1	-2	-2	5	1	-1	0	8	1	-1	3	1	9



How is a good multiple alignment obtained?

- Can extend dynamic programming (DP) method (Smith-Waterman or Needleman-Wunch) to $N > 2$ sequences

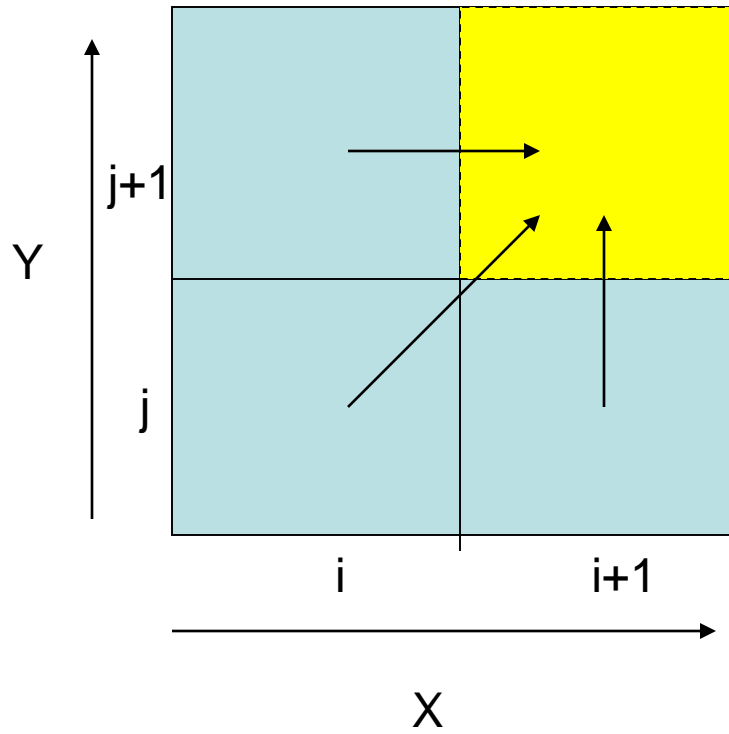

$$\max \begin{cases} X & X & \text{---} \\ Y & \text{---} & Y \end{cases}$$

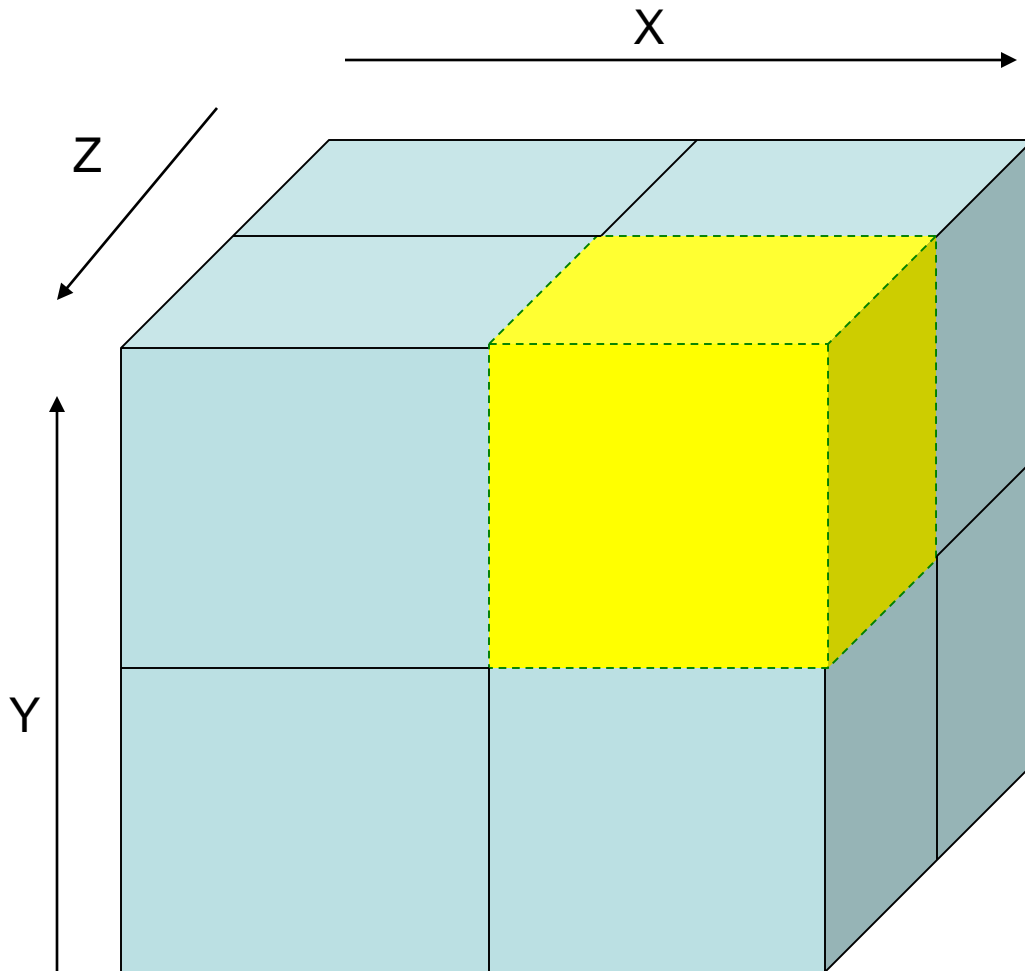

The seven neighboring cells are the seven possible paths for the optimal alignment

$$\max \left\{ \begin{array}{c|c|c|c|c|c|c} X & X & X & X & -- & -- & -- \\ Y & Y & -- & -- & Y & Y & - \\ Z & - & Z & - & Z & - & Z \end{array} \right.$$



DP on multiple sequences

- **Can extend standard DP to N sequences by using N-dimensional matrix, filling in optimal scores for each element using a defined scoring system, such as sum-of-pairs**
- **Problem: complexity is $O(L^N)$ for N sequences of length L**



Impact of Computational Complexity

- ⦿ **Suppose your algorithm can run on $N=10$ sequences of length $L=1000$.**
- ⦿ **You then get 1000 times as much of the limiting resource.**
- ⦿ **How many sequences can you now run on, as a function of the complexity $O(..)$ of that limiting resource?**



Initially $N=10$ and
 $L=1000$

Then increase limiting
resource by 1000-fold:
 $N \rightarrow 10000$

Assuming overhead
costs and all other terms
are negligible.

Algorithm Complexity	New problem size
$O(N)$	10,000
$O(N \log N)$	$\sim 40,000$
$O(N^2)$	10^8
$O(N^3)$	10^{12}
$O(L^N)$	10^{30000}



Making multiple sequence alignment more efficient. MSA program uses pair-wise alignments to define “search space” in which to apply DP to find optimal alignment. Doesn't have to fill in entire N-dim matrix, only those sections that can contribute to the optimal alignment. Uses branch-and-bound to determine the alignment space to be considered.

Proc. Natl. Acad. Sci. USA
Vol. 86, pp. 4412–4415, June 1989
Biochemistry

A tool for multiple sequence alignment

(proteins/structure/evolution/dynamic programming)

DAVID J. LIPMAN*†, STEPHEN F. ALTSCHUL*†, AND JOHN D. KECECIOGLU‡



Determining and displaying sub-optimal alignments. Can be used to set boundaries for MSA

$$M(x,y) = \text{Forward}(x,y) + \text{Backward}(x,y)$$

Can show all cells within some % of optimum score. Can be used to define boundaries for multi-sequence optimization.

Zuker, M (1991) JMB 221:403-420

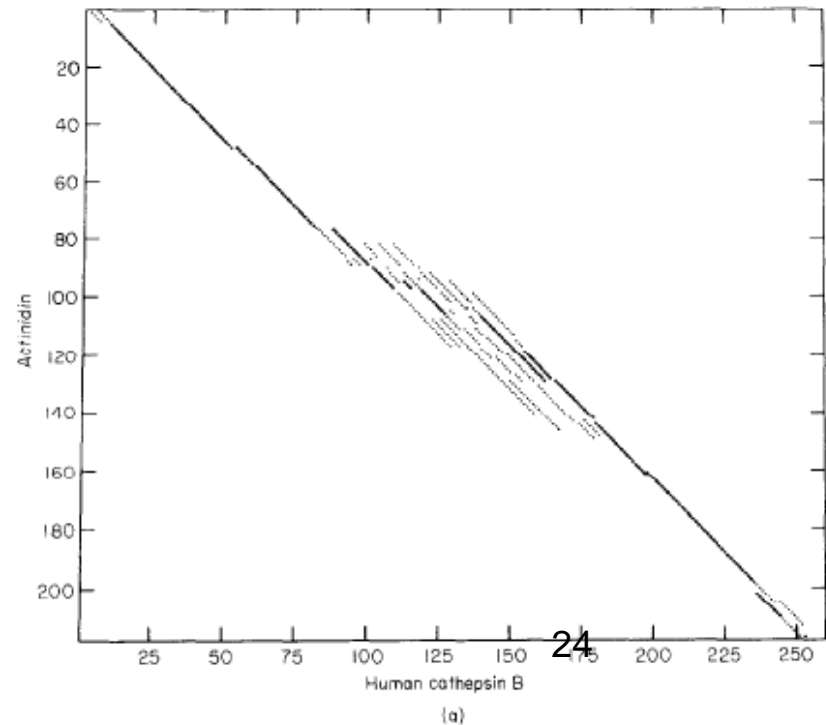
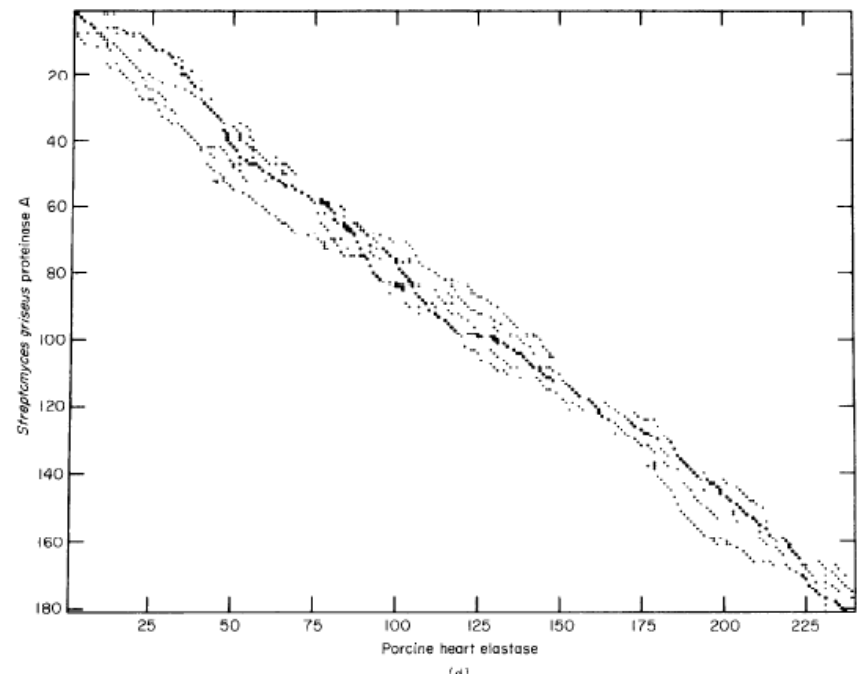



How is a good multiple alignment obtained?

- Can extend standard dynamic programming (DP) method (Smith-Waterman or Needleman-Wunch) to $N > 2$ sequences
 - $O(L^N)$ limits applicability
- Need good heuristic that returns near-optimal alignments in reasonable time/space



“Progressive Alignment”

- ④ **Always do pairwise alignments**
- ④ **Use DP to get optimal alignment of pairs**
- ④ **Once a pair is aligned, that alignment is fixed in subsequent steps**
- ④ **Some programs allow for the revising of previous steps, optimization of total score**

CLUSTAL W: improving the sensitivity of progressive multiple sequence alignment through sequence weighting, position-specific gap penalties and weight matrix choice

Julie D.Thompson, Desmond G.Higgins* and Toby J.Gibson*

European Molecular Biology Laboratory, Postfach 102209, Meyerhofstrasse 1, D-69012 Heidelberg, Germany

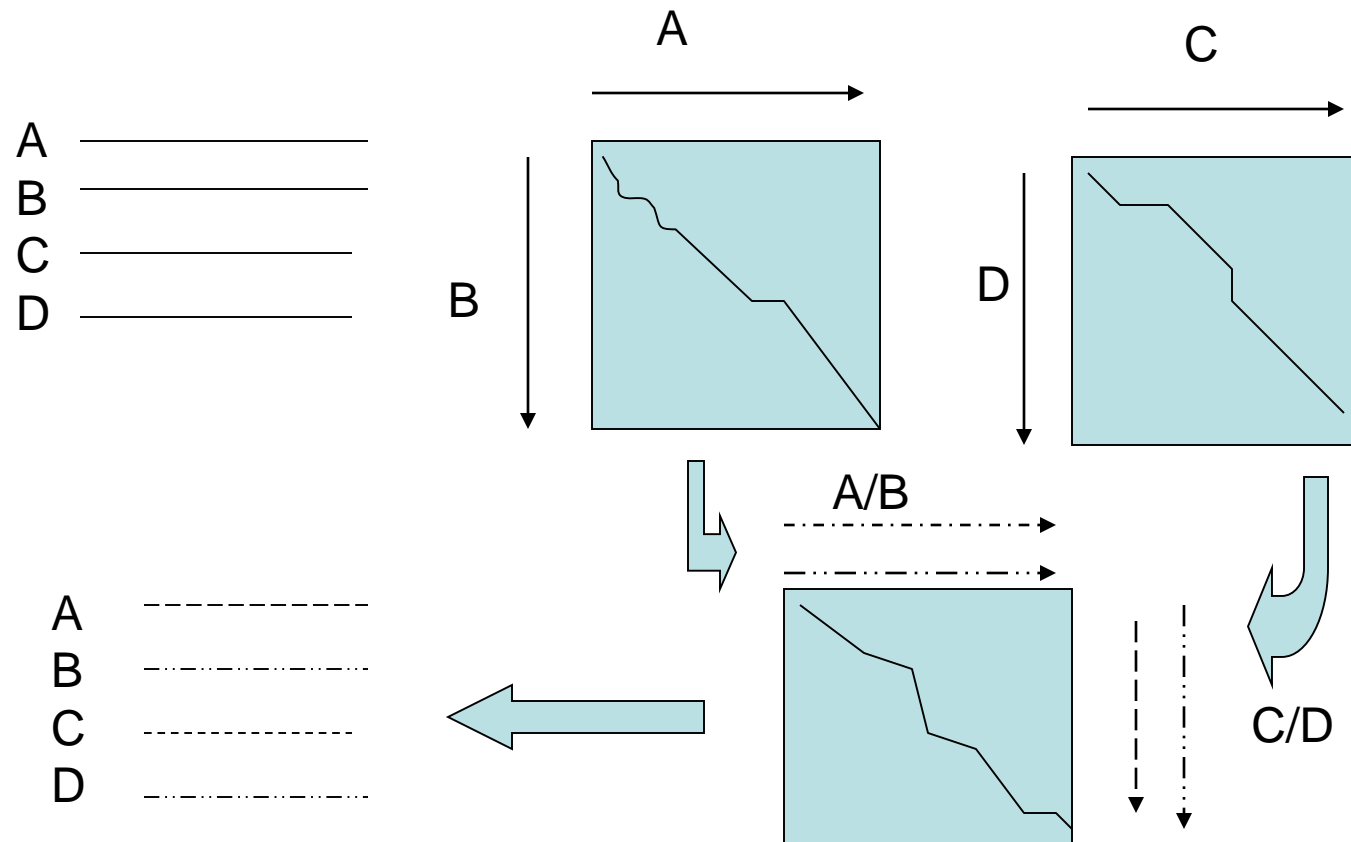



Sequence weighting:

Based on shared tree lengths, avoids problems from overly biased samples

```

1  peeksavt|al
2  geekaav|al
3  padktnv|kaa
4  aadktnv|kaa

```

```

5  egewqlvlhv
6  aaektkirsa

```

Without sequence Weights:

$$\begin{aligned}
 \text{Score} &= M(t, v) \\
 &+ M(t, l) \\
 &+ M(l, v) \\
 &+ M(l, l) \\
 &+ M(k, v) \\
 &+ M(k, l) \\
 &+ M(k, v) \\
 &+ M(k, l) / 8
 \end{aligned}$$

With sequence Weights W_i :

$$\begin{aligned}
 \text{Score} &= M(t, v) * W_1 * W_5 \\
 &+ M(t, l) * W_1 * W_6 \\
 &+ M(l, v) * W_2 * W_5 \\
 &+ M(l, l) * W_2 * W_6 \\
 &+ M(k, v) * W_3 * W_5 \\
 &+ M(k, l) * W_3 * W_6 \\
 &+ M(k, v) * W_4 * W_5 \\
 &+ M(k, l) * W_4 * W_6 / 8
 \end{aligned}$$

Gap penalty adjustment:

Increases/reduces gap opening penalty depending on local alignment features; New gaps cluster with previous ones, and in hydrophilic regions

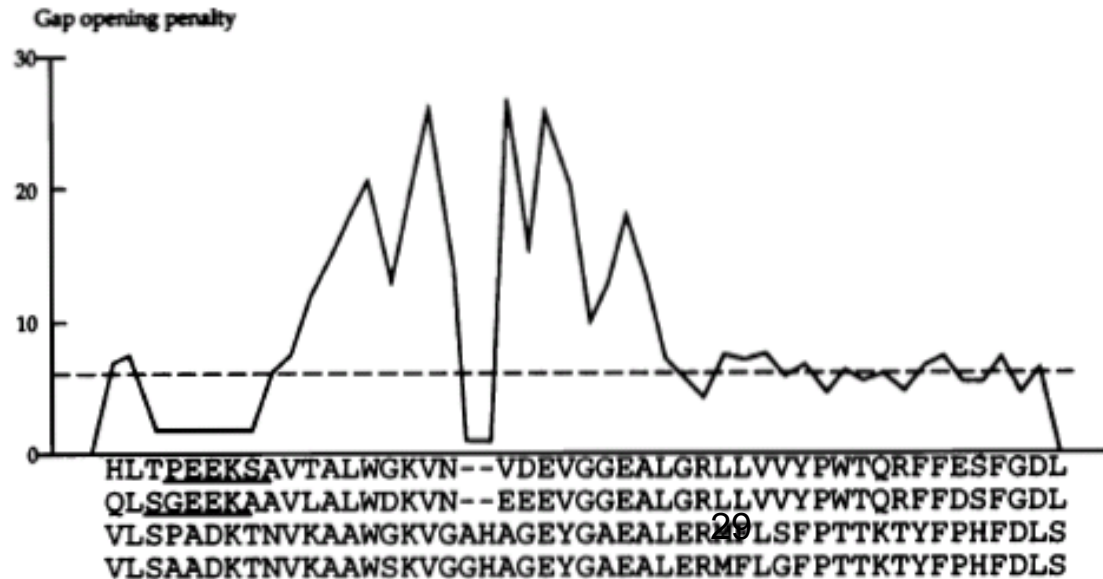



Multiple Alignment Lecture 2

Improved Progressive Alignments

- **Faster**
- **More accurate**
- **Consistency objective**

Alternative scoring systems

Position-specific scoring (Profiles)

Probabilistic modeling: Profile-HMMs

More recent improved methods

Faster and/or more accurate

- *See recent reviews by:*
 - *Edgar and Batzoglou, Current Opin. Struct. Biol. (2006) 16:368-373*
 - *Notredame, PLoS Comp Biol. (2007) 3:e123*
- FFT for speed; combine local and global alignments; iterative refinements; use additional types of information (such as structure) if available; maximize consistency with pairwise alignments

MAFFT - multiple alignment using Fast Fourier Transform, Katoh et al., Nucleic Acids Res. 30:3059-3066 (2002)

- Recode aa sequence into lists of properties (e.g. volume, polarity)
- Considering all possible shifts of ungapped sequences, identify the shifts with high similarity
- Can be computed in $O(L/nL)$ time instead of $O(L^2)$

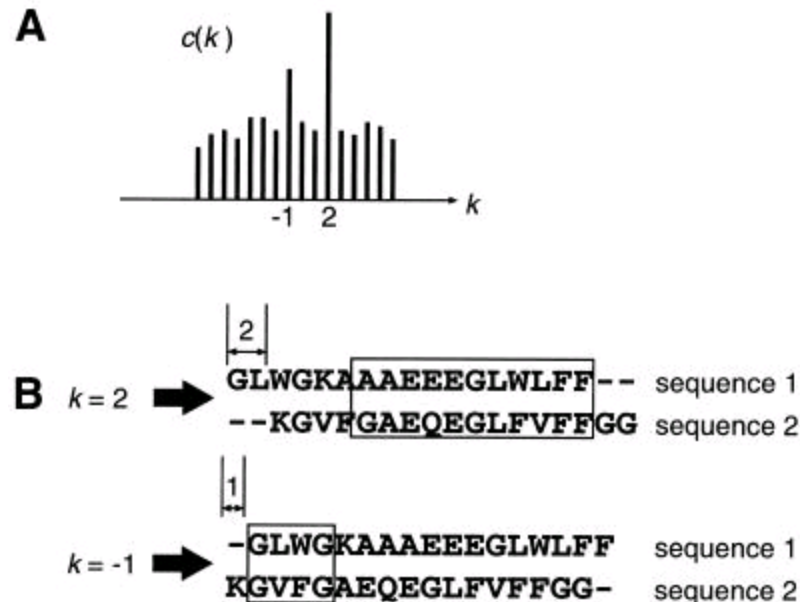



- Gives locally aligned, ungapped segments
- Can be “stitched” together with DP to give global alignment

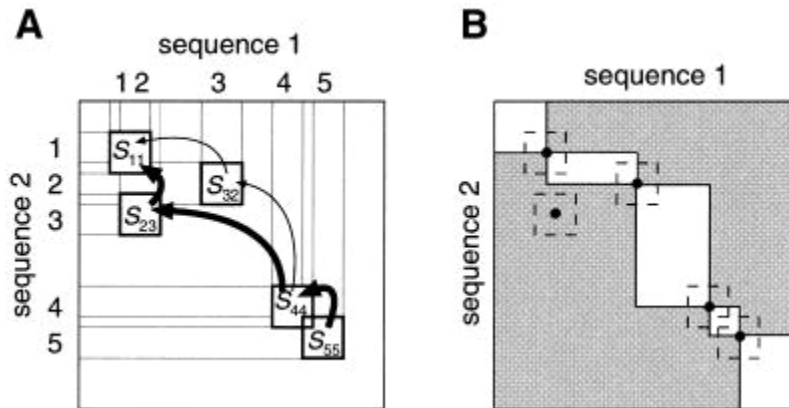

- The order of pairwise alignments is still based on a guide tree
- The whole process can be iterated to refine the alignment
 - At each iteration the alignment from the previous iteration is used for the guide tree, and the overall alignment can be broken into pieces that are optimized separately



MUSCLE: a multiple sequence alignment method with reduced time and space complexity, RC Edgar, BMC Bioinformatics 5:113

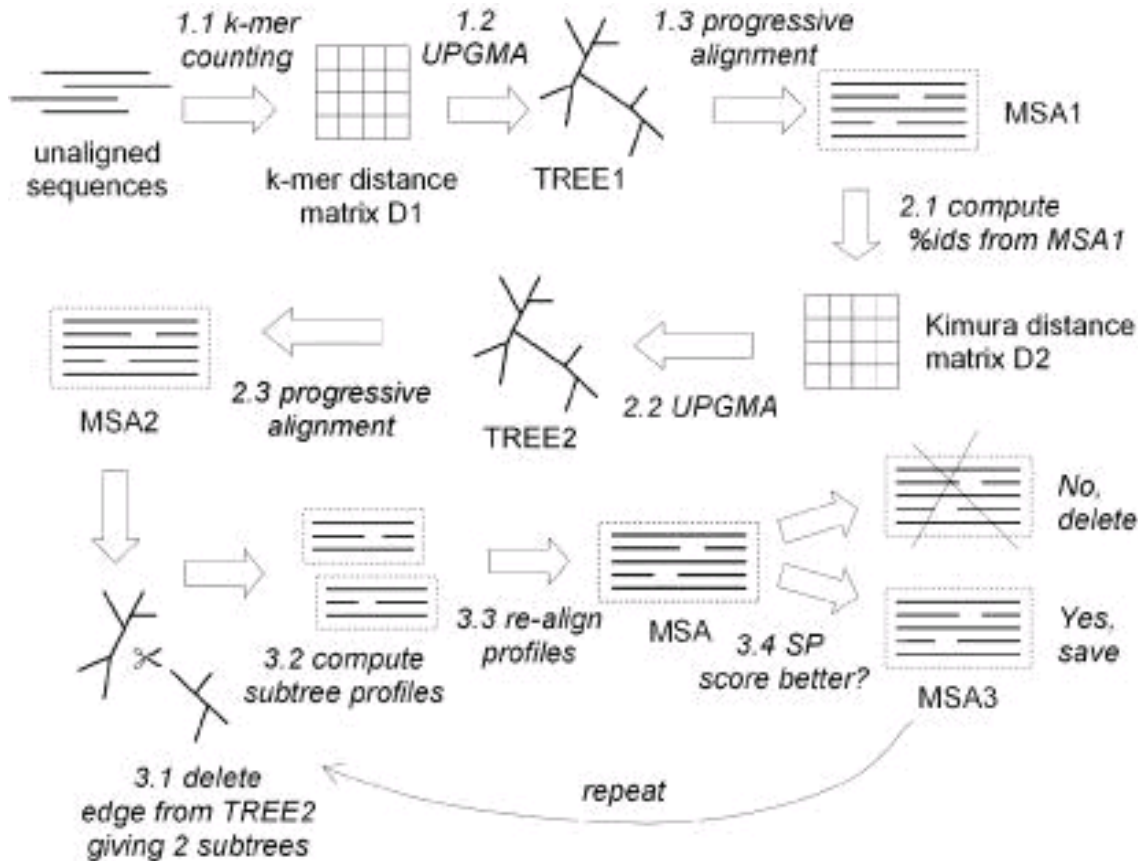

If only first 2 steps:
 $O(N^2L + NL^2)$

If third refinement step is included:
 $O(N^3L)$

Avoids first step, all-by-all alignment from ClustalW, which is $O(N^2L^2)$



An alternative scoring system (objective function)

- Maximize consistency in multiple alignment with each of the optimal pairwise alignments
- Basic idea: given three sequences A, B, C
Pairwise alignments of A:B and B:C
infers an alignment of A:C
How well does that match the pairwise alignment of A:C ?

Goal: Find most consistent multiple alignment.

ProbCons: Probabilistic consistency-based multiple sequence alignment

Chuong B. Do, Mahathi S.P. Mahabhashyam, Michael Brudno and Serafim Batzoglou

Genome Res. 2005 15: 330-340

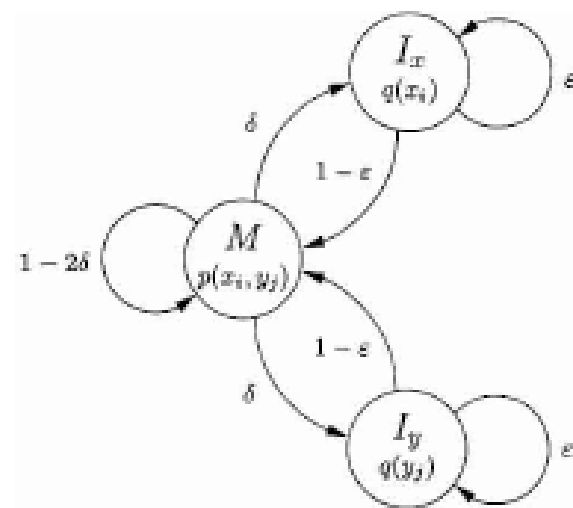

Figure 1. Basic pair-HMM for sequence alignment between two sequences, x and y . State M emits two letters, one from each sequence, and corresponds to the two letters being aligned together. State I_x emits a letter in sequence x that is aligned to a gap, and similarly state I_y emits a letter in sequence y that is aligned to a gap. Finding the most likely alignment according to this model by using the Viterbi algorithm corresponds to applying Needleman-Wunsch with appropriate parameters. The logarithm of the emission probability function $p(\cdot, \cdot)$ at M corresponds to a substitution scoring matrix, while affine gap penalty parameters can be derived from the transition probabilities δ and ϵ (Durbin et al. 1998).



ProbsCon details:

1. Pairwise alignment probabilities for all pairs of sequences; forward-backward using a similarity matrix (BLOSSUM62)
2. Find maximum *expected accuracy* alignment; i.e. alignment with maximum number of expected correct aligned pairs
3. Probabilistic consistency transform; find highest accuracy alignment of X:Y by $\sum_Z \sum_k P(x_i:z_k)P(y_j:z_k)$
4. Guide tree determination based on expected accuracy
5. Progressive alignment based on expected accuracy

Refinement can be done at the end if desired



Revisit the scoring system issue

- ④ **Sum-of-Pairs (SoP) assumes a single similarity matrix is appropriate for all positions – the same as for pair-wise alignments**
- ④ **Want to have a position specific scoring matrix (PSSM) – Profiles implement this using SoP**
- ④ **HMM-profiles provide probabilistic scoring that is position specific**

Profile analysis: Detection of distantly related proteins

(amino acid/sequence comparison/protein structure/globin structure/immunoglobulin structure)

MICHAEL GRIBSKOV*, ANDREW D. McLACHLAN†, AND DAVID EISENBERG*

b

POS	PROBE	CONSENSUS	PROFILE																				
			A	C	D	E	F	G	H	I	K	L	M	N	P	Q	R	S	T	V	W	Y	+/-
1	EGVVL	V	3	-2	3	4	0	4	-1	3	-1	4	4	1	1	-2	1	2	6	-6	-2	9	
2	LLSP	L	2	-2	-2	-1	3	0	-1	3	-1	6	5	-1	3	0	-1	3	1	4	1	-1	9
3	VVVV	V	2	2	-2	-2	2	2	-3	11	-2	8	6	-2	1	-2	-2	0	2	15	-9	-1	9
4	KEAT	A	6	-2	5	6	-5	4	1	0	5	-2	0	3	3	3	1	3	6	0	-6	-4	9
5	APLP	P	6	-1	0	1	-2	2	0	1	0	2	2	0	8	2	0	2	2	3	-5	-4	9
6	GGGG	G	7	1	7	5	-6	15	-1	-3	0	-4	-3	4	3	2	-3	6	4	2	-11	-7	9
7	SSQE	D	4	-1	7	7	-6	7	2	-2	2	-3	-2	4	3	6	1	6	2	-1	-6	-5	9
8	SSTP	S	4	4	2	2	-4	4	-1	0	2	-3	-2	2	7	0	1	10	6	0	-2	-4	9
9	VLVA	V	5	0	-1	-1	3	1	-2	7	-2	7	6	-1	1	-1	-3	0	2	10	-5	-1	9
10	KRRS	R	0	-1	1	1	-5	0	2	-2	8	-3	1	3	3	3	10	5	1	-2	7	-5	9
11	MLII	I	0	-2	-3	-2	7	-3	-3	11	-1	11	10	-2	-2	-1	-2	-2	1	9	-3	1	9
12	SSTS	S	4	6	2	2	-3	5	-1	0	2	-3	-2	3	4	-1	1	12	6	0	0	-4	9
13	CCCC	C	3	15	-5	-5	-1	2	-1	3	-5	-8	-6	-3	1	-6	-3	7	3	3	-13	10	9
14	KSQR	K	1	-2	3	3	-6	1	3	-2	7	-3	0	3	3	5	7	4	1	-2	2	-5	9
15	AAGS	A	10	3	4	3	-5	8	-1	-1	1	-2	-1	3	4	1	-2	7	4	2	-6	-4	9
16	TSDS	S	4	3	5	4	-5	6	0	0	2	-3	-2	4	3	1	1	9	6	0	-3	-4	9
17	GGSQ	G	5	1	6	5	-6	9	1	-2	1	-3	-2	4	3	4	0	6	3	0	-6	-6	9
18	YFLS	F	-1	2	-4	-3	9	-3	0	4	-3	6	3	-1	-3	-3	-3	1	-1	2	7	7	9
19	TTRL	T	1	-2	0	1	0	0	0	2	2	2	3	1	1	1	3	1	7	2	1	-2	9
20	FF.L	F	-2	-3	-6	-4	10	-4	-1	6	-4	9	6	-3	-4	-4	-3	-2	-1	3	7	8	4
21	SS.D	S	3	2	5	4	-4	5	0	-1	2	-3	-2	4	3	1	1	8	2	-1	-2	-3	4
22	S.SS	S	2	3	1	1	-2	3	-1	0	1	-2	-1	2	2	0	1	8	2	0	1	-2	4
23	. . . G	G	2	0	2	1	-2	4	0	0	0	-1	-1	1	1	1	-1	2	1	1	-3	-2	4
24	. . . D	D	1	-1	4	3	-2	2	1	0	1	-1	-1	2	1	2	0	1	1	0	-3	-1	4
25	. . . G	G	2	0	2	1	-2	4	0	0	0	-1	-1	1	1	1	-1	2	1	1	-3	-2	4
26	. AGN	A	6	0	4	3	-4	6	1	-1	1	-2	-1	5	2	2	-1	3	3	1	-5	-3	4
27	YNYT	Y	0	5	0	-1	5	-1	2	1	-1	0	-1	4	-3	-2	-2	0	3	0	3	6	4
28	EDDY	D	2	-2	9	8	-3	3	4	-1	1	-3	-2	5	-1	4	-1	1	1	-1	-6	0	9
29	LMAL	L	3	-5	-3	-1	6	-1	-2	6	-1	10	10	-2	0	0	-2	-1	0	6	-1	0	9
30	YNAW	N	4	1	3	2	0	2	3	-1	1	-1	-1	8	0	1	-1	2	1	-1	-1	2	9
.
48	SGNS	S	4	3	5	3	-4	7	0	-2	2	-4	-3	6	3	1	0	10	3	0	-2	-4	39
49	SSNY	S	2	5	2	1	1	2	1	0	1	-2	-2	5	1	-1	0	8	1	-1	3	1	9



Profile HMMs

J. Mol. Biol. (1994) 235, 1501–1531

Hidden Markov Models in Computational Biology Applications to Protein Modeling

Anders Krogh^{1†}, Michael Brown¹, I. Saira Mian²
Kimmen Sjölander¹ and David Haussler^{1‡}

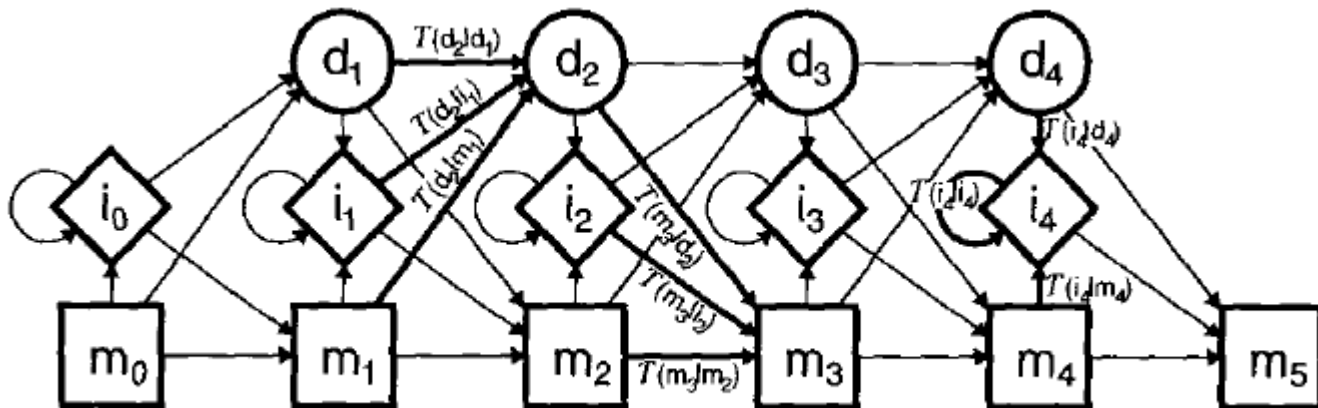
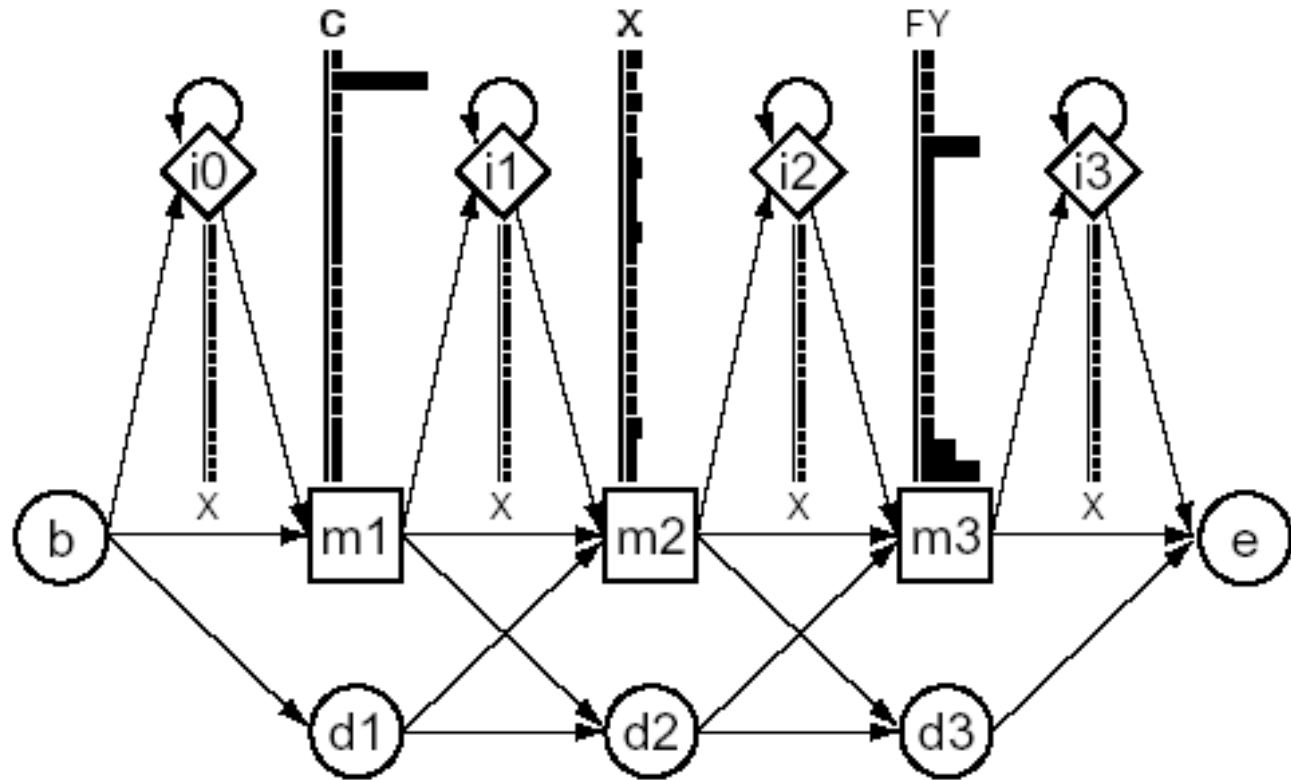

Figure 1. The model.



1	2	3
C	A	F
C	G	W
C	D	Y
C	V	F
C	K	Y



Review: “Profile hidden Markov models”
 by Eddy SR. *Bioinformatics*. 1998;14(9):755-63.

HMM-Profiles:

- Given an alignment, can estimate parameters
 - Emission Probabilities
 - Transition probabilities
 - Pfam database of HMM-profiles
www.sanger.ac.uk/Software/Pfam/
- Given an HMM and another sequence, can find best alignment by Viterbi (i.e. DP)
- Can iterate between those steps (EM):
start with unaligned sequences and end up with an alignment and a model that represents the family

Limitations: over-fitting from small sample sizes
use of priors can help
choice of model architecture, refinement
weighting of sequence contributions



Parameters obtained from an alignment

- All of the transition and emission probabilities can be obtained from the alignment just by “counting” how often each occurs
- Need a large sample size to estimate all of the parameters accurately
- Can add pseudocounts to avoid 0's
 - Laplace “add 1” rule is common
- Can use more complex priors (Dirichlet) that differ for different residues and even mixtures of Dirichlet priors

Find best alignment of a sequence to an HMM

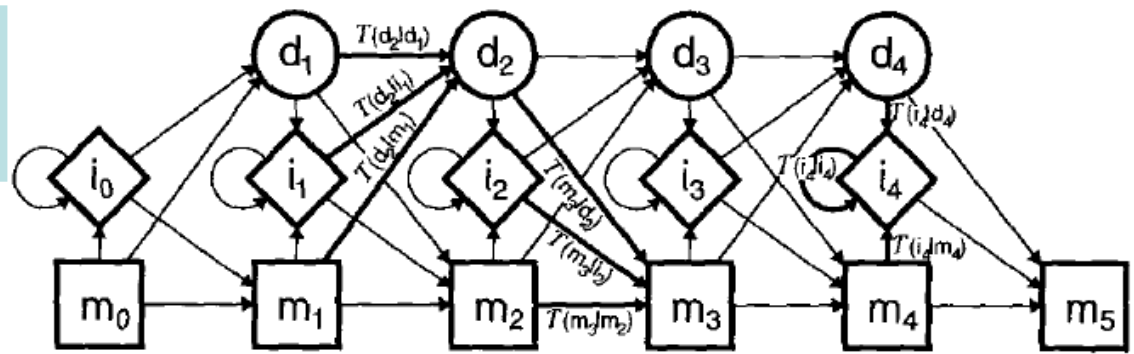

Figure 1. The model.

Viterbi algorithm

$$V_j^M(i) = \log \frac{e_{M_j}(x_i)}{q_{x_i}} + \max \begin{cases} V_{j-1}^M(i-1) + \log a_{M_{j-1}M_j} \\ V_{j-1}^I(i-1) + \log a_{I_{j-1}M_j} \\ V_{j-1}^D(i-1) + \log a_{D_{j-1}M_j} \end{cases}$$

$$V_j^I(i) = \log \frac{e_{I_j}(x_i)}{q_{x_i}} + \max \begin{cases} V_{j-1}^M(i-1) + \log a_{M_{j-1}I_j} \\ V_{j-1}^I(i-1) + \log a_{I_{j-1}I_j} \\ V_{j-1}^D(i-1) + \log a_{D_{j-1}I_j} \end{cases}$$

$$V_j^D(i) = \max \begin{cases} V_{j-1}^M(i-1) + \log a_{M_{j-1}D_j} \\ V_{j-1}^I(i-1) + \log a_{I_{j-1}D_j} \\ V_{j-1}^D(i-1) + \log a_{D_{j-1}D_j} \end{cases}$$

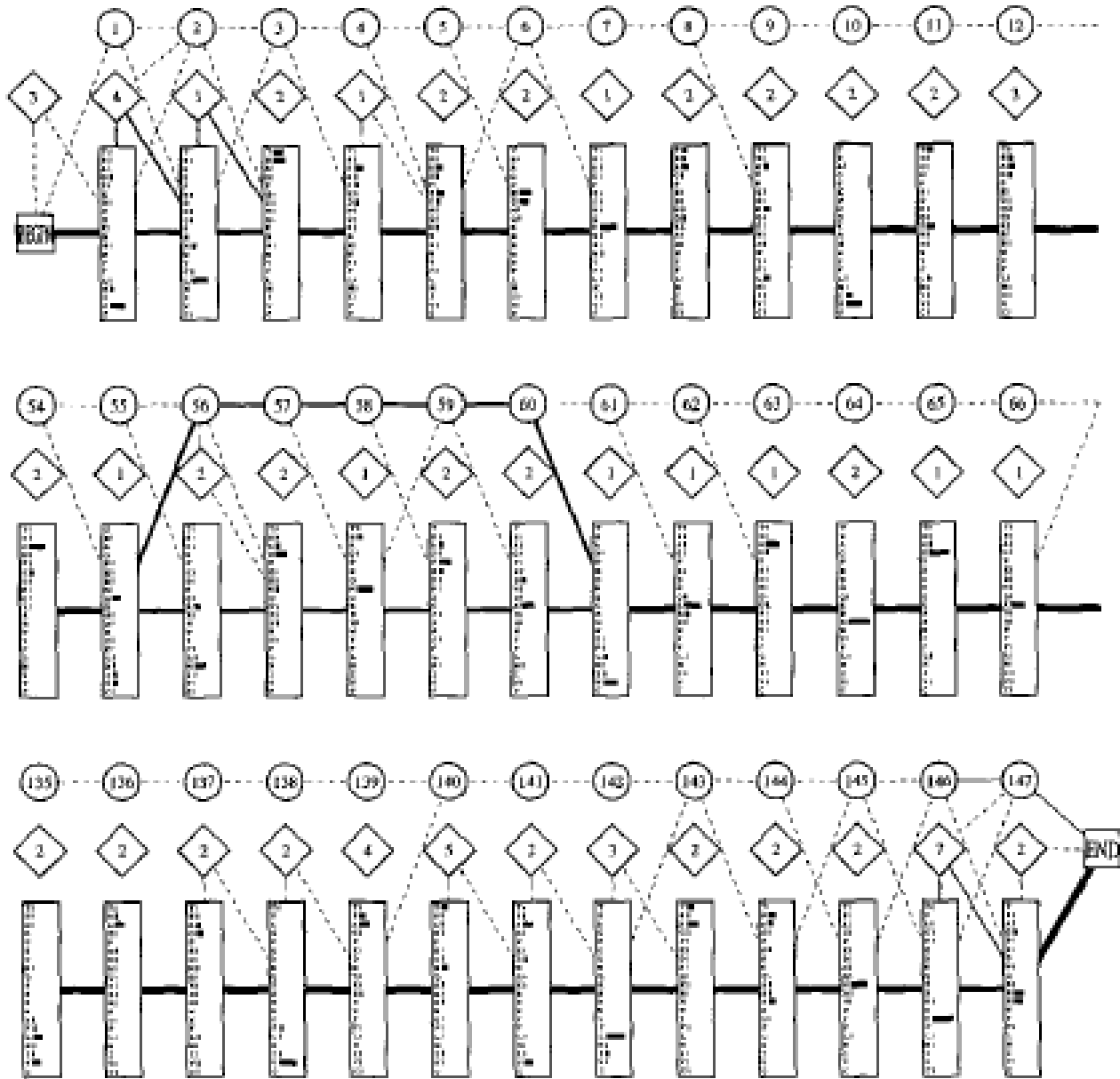

Figure 8. Parts of the final globin model. The position numbers are shown in the delete states.

Find probability that a sequence is “generated” by an HMM

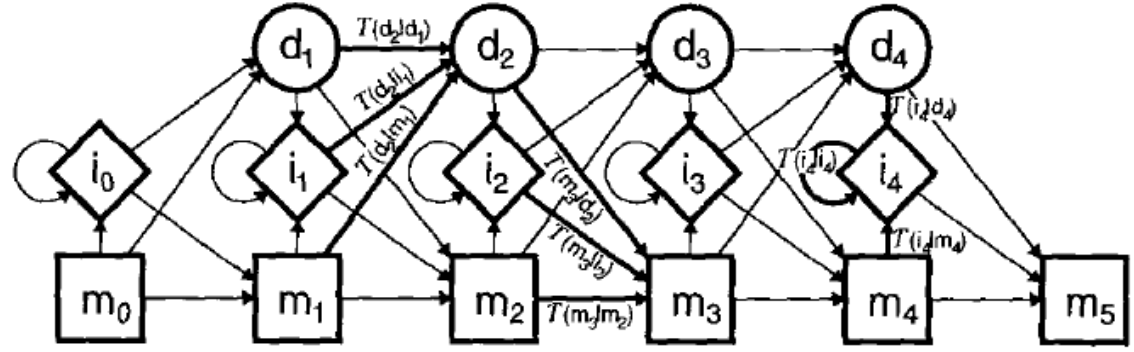

Figure 1. The model.

Forward algorithm

$$F_j^M(i) = \log \frac{e_{M_j}(x_i)}{q_{x_i}} + \log \begin{cases} a_{M_{j-1}M_j} \exp(F_{j-1}^M(i-1)) \\ + a_{I_{j-1}M_j} \exp(F_{j-1}^I(i-1)) \\ + a_{D_{j-1}M_j} \exp(F_{j-1}^D(i-1)) \end{cases}$$

$$F_j^I(i) = \log \frac{e_{I_j}(x_i)}{q_{x_i}} + \log \begin{cases} a_{M_{j-1}I_j} \exp(F_{j-1}^M(i-1)) \\ + a_{I_{j-1}I_j} \exp(F_{j-1}^I(i-1)) \\ + a_{D_{j-1}I_j} \exp(F_{j-1}^D(i-1)) \end{cases}$$

$$F_j^D(i) = \log \begin{cases} a_{M_{j-1}D_j} \exp(F_{j-1}^M(i-1)) \\ + a_{I_{j-1}D_j} \exp(F_{j-1}^I(i-1)) \\ + a_{D_{j-1}D_j} \exp(F_{j-1}^D(i-1)) \end{cases}$$



Acknowledgement

Most of the slides in this chapter were provided by Prof. Gary Stormo.